

May 27, 1930.

R. G. DREW

1,760,820

ADHESIVE TAPE

Filed May 28, 1928

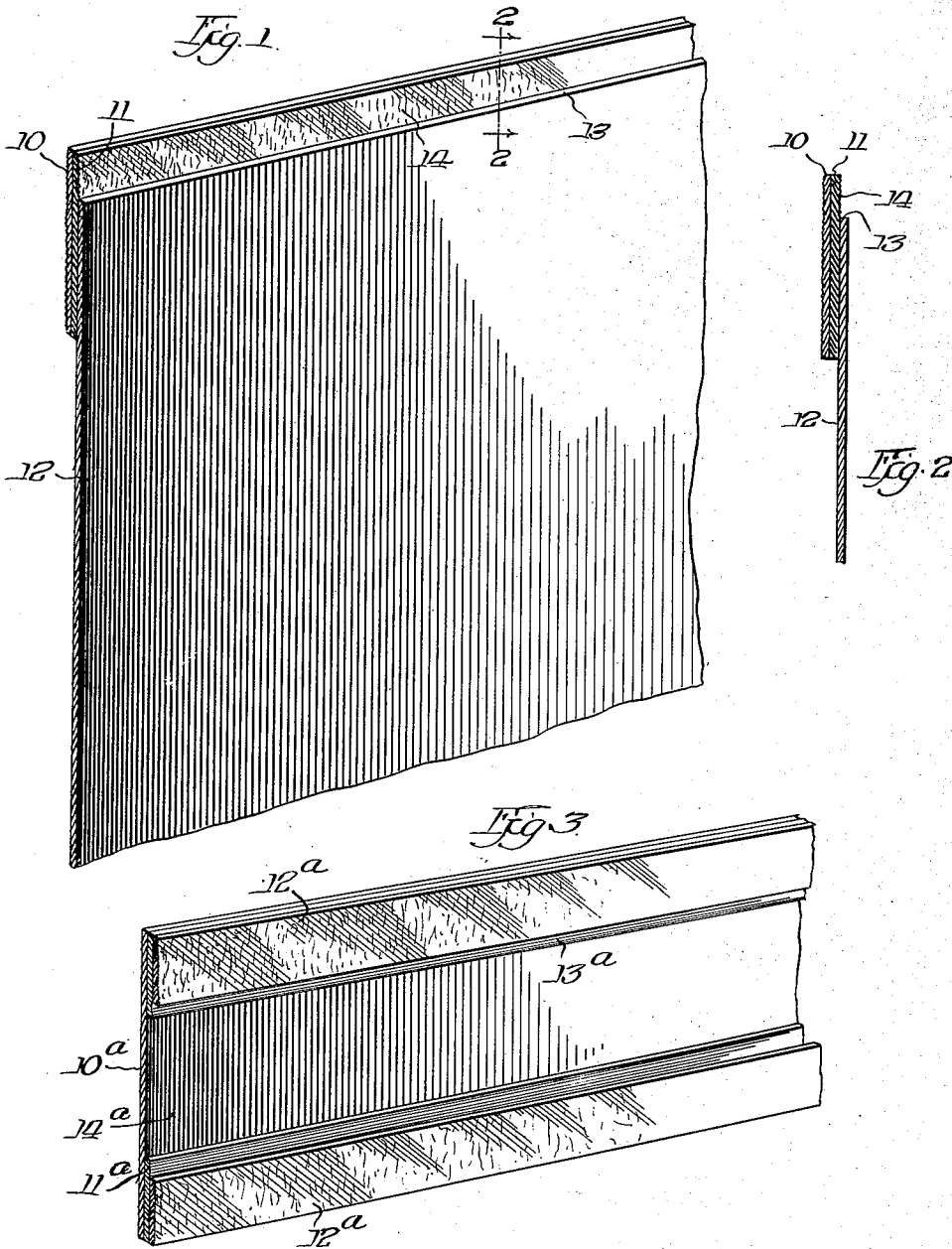

Witness:

*E. J. Adams*

Inventor

*Richard Lurley Drew*  
By attorney  
*Paul Carpenter*

# UNITED STATES PATENT OFFICE

RICHARD GURLEY DREW, OF ST. PAUL, MINNESOTA, ASSIGNOR TO MINNESOTA MINING & MANUFACTURING COMPANY, OF ST. PAUL, MINNESOTA, A CORPORATION OF MINNESOTA

ADHESIVE TAPE

Application filed May 28, 1928. Serial No. 281,104.

REISSUED

APR 9 1934

My invention relates in general to adhesives, adhesive compositions or adhesive sheets or coatings; more particularly to pressure energizable adhesives, adhesive sheets or coatings, preferably water insoluble and normally non-drying.

My invention is a continuation in part of my prior application, S. N. 182,893, filed April 11, 1927 for Adhesives in the form of sheets or the like and method of making the same.

While my invention has a broad field of usefulness, I have found it of peculiar utility for producing an adhesive coating for limiting the application of the spray of liquid finishing material, such as, for example, lacquers or painting materials used in operations in automobile body paint shops and therefore it convenient to describe the invention in connection with such practice and product, it being understood, however, that such fields of specific description are employed purely for purposes of illustration of an example of the utility of this invention in its several phases, besides other novel phases as may appear or be hereinafter pointed out.

In the work referred to specifically above, my improved material may be used directly as a coating or as an adhesive material for holding protective paper aprons or masks against surfaces on which it is not desired to apply a lacquer, paint, paint spray or lacquer spray, such as, for example, glass windows, upholstery, rubber mats, running boards, bright metal parts and wrapping material in general, and the like.

My product may also be applied to a surface which, in a subsequent step, is to be finished by an application of a lacquer spray or painting or to a surface which has been finished in order to prevent mingling of the colors, as for example, in two color work. My improved material may be applied to paper or similar fabric material in sheeted form and is capable of being stored in piled sheets or in laminations, as formed by rolling layers of material, such as tape, or such other form as may be proper for the purpose contemplated.

For certain preferred work, for advantages hereinafter pointed out, my improved ma-

terial may be applied to paper to impart minimum point contact and inherent elasticity by applying the same to paper which is tow-eled or crimped or otherwise shaped to present a surface other than flat and which has an extensibility beyond that of the flat paper web. Further, my improved material may be applied to completely or partially cover a backing material such as paper to present a surface which has minimum adhering surface, yet satisfies the requirements of a completely coated backing material.

It is to be observed that in finishing automobile bodies with lacquers, paints or the like of a plurality of colors, difficulty is found in limiting the application owing to the diffusion of the spray, where such is used, or requiring skillful application of the paint brush, when the latter is used. In order to obtain a clear and cleancut line of demarcation between several colors or within limited areas or applying a coating material within limited areas, masks or aprons in the form of adhesive tape have been used. These are of the general types comprising an insoluble zinc oxide adhesive coating and the rubber base adhesive coating as one group, both of which use a cloth backing, and the ordinary gummed paper tape, which forms an example of the other type. Both types of tape referred to present certain marked objections. As to the latter type, ordinary gum base tape is energized by wetting, objectionable in that it requires this wetting operation before application and still more objectionable in that it adheres so tenaciously that to remove the same requires softening of the adhesive material with large quantities of water for a long time and where this practice is resorted to the paper material becomes so weak as to laminate and tear and, to effect removal, sometimes necessitating scraping, tending to mar the underlying surface.

In the case of cloth backing, adhesive coated material, a rather expensive item is involved in the use of the cloth backing but this material is still further objectionable for use for the purpose contemplated in that the woven fabric is distensible to an extent which will make its edges irregular and unsuitable

55  
60  
65  
70  
75  
80  
85  
90  
95  
100

for stripping. Furthermore, the cloth is permeable to the solvents normally used in connection with lacquer whereby the adhesive coating will be disengaged and be left as a residue upon the body of the material.

5 Still further, a woven fabric, such as cloth, tends to unravel or leave a feathered edge and is, furthermore, of such thickness as to present a blurred effect at marginal edges of the paint or lacquer coating.

10 Still further, adhesive coatings, such as cloth back zinc oxide or rubber base type tapes are not only permeable to the solvents used in lacquering or painting operations 15 tending to disengage the adhesive and leave the same upon the work but when stacked in rolls or sheets, they are more permeable to atmospheric oxidation, tending to cause an unduly rapid deterioration of the adhesive material with a consequent loss of their 20 power of adhering to the object to which they are intended to be combined.

While for simplicity in describing the invention and as an example for making the 25 same, I have referred to a rubber base adhesive, it is understood that it is contemplated to employ a non-drying, pressure aggressive adhesive material and that this expression is used in the specification and claims in its 30 broadest sense.

Among the objects of my invention are the provision of an adhesive or coating material which is non-drying or becomes aggressive 35 by the application of pressure; the provision of an adhesive coating or coating material which becomes energizable by the application of pressure and without modification of the same by solvents or heat; the provision 40 of an adhesive or coating material upon an inexpensive base, such as sheeted material of paper, the same being non-drying and energizable by the application of pressure without the use of solvents or heat; the provision 45 of an adhesive upon a base of relatively non-distensible material such as paper, which may be applied to a lacquered, painted or varnished surface merely by the application of pressure of this member thereto and will present a straight edge; furthermore, 50 the provision of an adhesive upon a base or backing, the backing serving as an impermeable member to the solvents of such materials as paints or varnishes whereby an adhesive material applied to such work as the body 55 of an automobile will not have the adhesive coating thereof disengaged by the solvents of the lacquer, paint or varnish applied thereover; the provision of an adhesive coating material upon a base or backing, such as paper, which may be applied merely by the 60 application of pressure and which may be retained in superimposed layers thereof, such as stacks or piles or rolls without the use of slip sheeting whereby the back of the sheeting may be removed from the adherent coat

of an adjacent layer; the provision of a sheeted material having an adhesive coating, which is normally non-drying and pressure aggressive but which is so formed as to contact with 70 work upon which it is applied to have sufficient adhesiveness for its intended function of holding a sheeted material in position but without marring the work to which it is applied, characterized by coating a base or backing of paper which is creped, toweled 75 or otherwise formed to lessen contact over its entire area; the provision of a sheeted material having an adhesive coating thereon to limit the contact of the adhesive coating as by forming the paper by creping or toweling or localized application of the adhesive 80 coating to the surface of the sheeted material; the provision of a sheeted material having a pressure aggressive adhesive material which may be adhesively applied to a surface and separated therefrom without 85 splitting of the paper or marring of the body to which it is applied or leaving a residuum of the adhesive particularly after use in a painting operation by application of solvents 90 for the paint to the back side of the same.

A still further object of my invention resides in the provision of a sheeted material having a pressure aggressive coating thereon, the whole of which is relatively somewhat stretchable and somewhat resilient, 95 characterized by forming the backing from creped or toweled paper; the provision of a sheeted material having a paper or like base treated to render the same impermeable 100 to coating materials, such as lacquers, paints, varnishes or the like whereby solvents used in lacquers, paints, varnishes or the like will not disengage the adhesive material which may be mounted thereon; the provision of a 105 sheeted adhesive material having a paper base treated whereby a pressure aggressive adhesive may be applied thereto without permeating to the other side thereof; the provision of a sheeted adhesive material having 110 a calendered, or bibulous uncalendered paper base saturated with an adhesive material whereby an adhesive coating may be applied to the same for adhesively attaching the 115 same to a surface by the application of pressure and capable of being separated from such surface without tearing or splitting of the paper or leaving a residuum of the adhesive material upon the surface to which it is applied. 120

My invention still further has for an object thereof the provision of a sheeted material having a base such as paper, including on one surface thereof a non-drying adhesive coating comprising rubber and a resinous 125 material, the adhesive being energizable by the application of pressure and which is capable of retaining the adhesive character under the most adverse atmospheric conditions, the sheet being characterized by freedom 130

from loss of adhesiveness and material change of the rubber and which may be further stacked or piled without the use of slip sheeting characterized by the absence of permeation of the adhesive coating to the back surface of the sheet.

The invention still further has for an object thereof the provision of an adhesive tape material having a paper base in which the filamentary material of the paper is locked and is resistant to tearing and splitting when in contact with an adhesive surface; the provision of adhesive tape material having a paper base in which the filamentary material of the paper is locked and is resistant to tearing and splitting when in contact with an adhesive surface characterized by surface treating and saturating the paper with a glue or gelatin base material; the provision of a sheeted adhesive material having a paper base which is resistant to tearing and shock by forming the same from creped or toweled paper and surface treating or saturating the same with a glue or gelatin base material whereby a pressure aggressive water insoluble adhesive coating may be applied thereto; the provision of a sheeted material having a paper base, treated or saturated with a glue or gelatin base material and further surface treated with a separator material for an insoluble pressure aggressive coating whereby sheets may be rolled or stacked without the use of intermediate slip sheeting; the provision of a sheeted material having a paper base, surface treated or saturated with a glue or gelatin base composition and a flexibility augmenting agent including glycerine whereby the surface thereof may be substantially non-adherent to a non-drying, pressure aggressive adhesive material, such as zinc oxide or rubber base adhesives, to provide a material capable of being stacked, piled or rolled without the use of intermediate slip sheeting; the provision of a sheeted material having a paper base, having an adhesive applied to limited portions thereof, such as predetermined edges of one surface whereby limited adhesiveness may be had with covering capacity of the entire sheet.

To attain these objects and such further objects as may appear herein or be hereinafter pointed out, I make reference to the accompanying drawing forming a part hereof, in which—

Figure 1 is a perspective view illustrating my invention as applied for use in connection with a painter's mask;

Figure 2 is a section taken on the line 2—2 of Figure 1;

Figure 3 is a perspective view of another embodiment of my invention.

One embodiment of my invention is in the form of a sheeted material in the nature of a tape 10, of a paper base of the character hereinafter referred to and described and treat-

ed in accordance with an invention disclosed in my application S. N. 182,893, filed April 11, 1927, and is preferably a paper saturated with a glue or gelatin base and is coated on one face with a non-drying, pressure aggressive adhesive 11. In this form, to apply a mask or apron 12 for painting or lacquering operations, a sheeted material which may be paper or the like has attached thereto adjacent the edges 13 a strip of tape 10 and it is positioned so that a portion 14 projects beyond the edges 13. The projecting portion 14 may thereafter be applied to fasten the mask or apron wherever desired, duplicating the affixation of the attaching strip at opposite edges of this mask, it being understood, however, that the strip itself may be used to cover surfaces of its own width.

In Figure 3 I have illustrated another embodiment of my invention comprising an adhesive sheeted material in the nature of the tape 10<sup>a</sup> of a paper base of the character hereinafter described or treated in accordance with the process outlined in my application aforementioned. One face 11<sup>a</sup> has thereon edge strips of adhesive material 12<sup>a</sup>, preferably mounted upon an interposed priming coat layer 13<sup>a</sup>, thus forming spaced adhesive portions and intermediate, non-adhesive portion 14<sup>a</sup>, thereby providing a tape or sheet of limited adhesive contacting surface, though of covering capacity equivalent to the full width of the tape or sheet.

The paper base 10 may be any of the following, which I cite by way of example:

(a) Craft paper, regular sulfate paper, straight 100% wood pulp;

(b) Sulfite paper containing a goodly portion of cotton stock, suitably sized and maintained soft by additions of small quantities of glycerine;

(c) A parchmentized paper;

(d) A paper base which is preferably absorbent, approaching blotting paper, calendered or uncalendered; preferably, however, this paper base is of the unsized, uncalendered variety and is pressed, molded or otherwise formed with rugosities or corrugations to have the appearance of toweled fabric, such as by crimping or creping the same.

Paper of the character above described may have directly applied to one surface thereof a water-insoluble, non-drying adhesive, preferably energizable or active merely by the application of pressure, so-called a zinc oxide or rubber base adhesive for surgeon's or industrial tape. This adhesive material may be given as follows:

#### *Example A*

A rubber compound and tackiness augmenting agent in the form of a synthetic resin. Proportions suitable for ordinary temperate climates may comprise:—

10 lbs. of plasticized, first quality planta-

tion rubber, such as clear crepe or smoked sheets.

2 lbs. of cumaron gum or resin.

$\frac{1}{2}$  lb. of zinc oxide pigment.

5 The cumaron gum or resin is preferably an artificial resinous material coming under the group name of cumaron and indene resins, which is the polymerization product of coal tar derivatives. The above ingredients are  
10 compounded on a rubber rolling mill to a plastic condition and then cut to desired body or consistency, using a rubber solvent such as benzol or a petroleum solvent, such as high test gasoline.

15 In lieu of a synthetic resin I may employ a low boiling point natural resin, e. g., Burgundy pitch or pine oil foots. Burgundy pitch is soluble in both alcohol and benzol.

#### Example B

20 2 lbs. of plantation rubber.

5 lbs. of Mexican or wild rubber, high in natural resin content.

1 lb. of zinc oxide pigment.

25 The ingredients above enumerated are compounded on a rubber mixing roll and then cut to the desired consistency in a rubber solvent, based upon the necessity viscosity for spreading this material. Ordinarily, in  
30 both Examples A and B, the solvent is calculated by the number of pounds of solid compound in one gallon of solvent such as, for instance, 8 lbs. of solid or compounded material and 1 gallon of benzol, which is commonly referred to as an 8 pound cut. The  
35 variations in proportions of solvent added will depend upon the desired thickness of adhesive coating required in the residuum.

40 It will be understood that the examples above given are for purposes of getting the requisite adhesiveness in temperate climates. An increase in resinous material or wild rubber may be made for material to be used in colder climates and in warmer climates the  
45 resin component may be reduced.

The resinous component may also be varied in its characteristics in its reactions to solvents by choice of the resinous material. Thus, for purposes of removal of the adhesive  
50 from some body to which it may be applied, it may be made soluble to various organic solvents, either benzol, gasoline, acetone or alcohol. Thus, where it is desirable to make a surgeon's tape, which is soluble in alcohol,  
55 an alcohol soluble resin is added in the examples above cited. Such resin may be Burgundy pitch. This will permit alcohol to be used in removing a piece of adhesive tape from any surface, such as from the skin  
60 of a patient, by merely soaking the backing of the tape in alcohol. The rubber, in any event, merely acts as a vehicle for the resin and the character of the adhesive in its re-  
65 action to solvents will be dependent upon

the character of the resin incorporated with the rubber.

The rubber resin compounds in their solvents may be spread upon the paper backing directly, utilizing a knife spreader to uniformly and equally distribute this material upon the base or backing. The solvent may thereafter be removed by evaporation, preferably without recovering the solvent and leaving the rubber mixture upon the paper  
70 backing. 75

Though I may directly apply the rubber in its solvent upon a paper backing, particularly of the character above indicated as craft or white paper, it is preferred to preliminarily  
80 treat the paper with sizing coats, priming coats or separator coats.

Though, as above described, I may use the craft paper, white paper or parchmented paper directly for a base or backing for the rubber adhesive, it is preferred to treat one side of the paper with a rubber primer and the opposite side of the paper with a rubber finisher and then applying the rubber adhesive to the side of the paper first treated with the rubber primer after first preferably treating the paper, especially where that hereinabove exemplified as A, B or D is used, with a glue-glycerine solution insolublized and preferably flexiblized by the process herein described and more particularly referred to in my application, S. N. 182,893.

The rubber primer is preferably a very light solution of rubber, which will leave a very thin residue of rubber, preferably tacky and to render the adhesive coating more amenable to adhesion therewith. The rubber finisher is preferably a solution of rubber which will leave a modified rubber deposit, such as chlorinated rubber or vulcanized rubber, thus leaving a residuum of rubber which is non-tacky and non-adherent to the touch of the hand or when stacked or rolled, will be capable of ready separation from the adhesive face. Tape so made can be wound up in rolls without slip sheeting and unwound successfully.

An example of a rubber primer as above used is as follows:

100 parts by weight of milled plantation rubber. 115

$7\frac{1}{2}$  parts by weight of phenolsulphonic acid.

This combination is formed in sheets and subjected to an oven temperature of 135 to 140 degrees centigrade for approximately six hours. The resulting product is flexible, and when dissolved in benzol forms an extremely liquid solution. 120

Untreated, smoked sheets, when cut in benzol, will form a very heavy, viscous and gelatinous solution. 125

Conversion of rubber into thermoplastic products, can also be accomplished by using 130

other reagents, such as toluenesulphonyl chloride and toluenesulphonic acid.

An example of a rubber finisher as above referred to may be made as follows:

Plantation rubber dissolved in a suitable solvent, such as benzol, is placed in an agitator into which a small stream of chlorine gas is allowed to flow. The temperature is checked by artificial refrigeration, and the chlorine treatment continued until the rubber solution has become about 55% chlorine saturated. Beyond this point free chlorine escapes, which is not desirable.

It will be understood that I may, for certain purposes, substitute for the rubber finisher coat a treatment such as outlined in my application S. N. 182,893 and the means therein described for assuring separation between the back of one sheet and the adhesive surface on the opposite side of an adjacent layer.

In the practice of my invention utilizing parchmented paper, the adhesive base may be applied directly thereto. It is preferred to treat the back with glycerine or a glue-glycerine mixture and the opposite side, before applying the rubber adhesive, with a rubber priming coat—still further, by substituting for the glue-glycerine back size a rubber finisher coat as in the example above described. The back of the parchmented paper, whether including a back size or rubber finisher coat, or not, may be improved during its manufacture or subsequently by the addition thereto of a thin coating of glycerine.

Unsize craft paper or the creped, towed paper above referred to may be used directly for applying thereto to rubber adhesive, preferably first interposing the finishing coat on the back and the priming coat on the front before applying this adhesive coating. Preferably, where the paper is of the unsize, uncalendered variety, the fibres thereof may be strengthened by treatment with a glue-glycerine solution to completely bond the fibres and may be insolubilized or tanned and have the flexibility thereof augmented by the process described in my application S. N. 182,893. Paper so treated, particularly as a result of first saturating with glue-glycerine and treatment with formaldehyde, forms a splendid base for the rubber primer, it being understood that I may treat the paper with glycerine or glue-glycerine after first applying a rubber priming coat; in which case it forms a layer to seal the surface of the paper, preventing the glycerine or glue-glycerine from penetrating into the rubber primer, and thus weakening the adhesiveness of the rubber. The fibrous material of the paper is bonded against lamination and is highly flexible. Economy is also effected in the amount of glue and glycerine necessary for saturating the paper base. I find that where the back of

the paper is so treated, the primer adheres more firmly thereto.

A paper base of the character above described may be treated with a glue base saturating solution or an insoluble solution. For this purpose, the paper base is first sized with a solution of polyhydric resin, a synthetic resinous material resulting from the reaction, condensation or polymerization of polyhydric alcohols or their anhydrides or similar compounds or polyhydric acids or their anhydrides. This center sizing material for the paper base may have its flexibility suitably augmented and upon evaporation of the vehicle there may be applied the rubber adhesive layer, preferably by first treating one side with a rubber primer and back sized with a rubber finisher of the character hereinabove referred to.

For making a paper base or backing, the paper is first submitted to a preliminary treatment by a saturating solution involving a glue base. The saturating solution of the following materials in proportions represent my preferred practice:—

36 pounds of dry glue  
72 pounds of water

108 pounds (approx. 16° Twaddell) glue solution.

Complete swelling is permitted, assisted by warming.

To this is then added 108 pounds of yellow glycerine.

108 pounds (approx. 16° Twaddell) glue solution

108 pounds pale yellow glycerine

216 pounds glue-glycerine water solution.

To this is added 216 pounds of water.

216 pounds glue-glycerine water solution

216 pounds water

432 pounds.

The paper above described is preferably continuously submerged and passed through a bath of the saturating solution as above prepared and then passed through pressure rolls to squeeze off the excess and then dried by heating. It will be observed that just complete saturation is preferred as this step is closely related to the success or failure of the treatment. An insufficient saturation will be characterized by failure to completely bond the fibres of the unsize paper nor will the saturating solution be present on the back side. An over-sufficient saturation of the paper will render the surface unfit for subsequent coating, which will be observed as this description proceeds.

A paper so treated will be found to have the fibres thereof locked to materially strengthen the paper web and provide a

highly flexible sheet. Where I use the tow-  
eled or creped variety of paper, this sheet  
will be found to be substantially elastic and  
resistant to tearing by shock, as where using  
5 the same for wrapping purposes.

Prior to the drying step above mentioned,  
in one form of the practice of my invention,  
after the paper has been saturated and passed  
through the pressure rolls, the web of material  
10 is subjected to a treatment tending to  
insolubilize or tan the glue. The insolubilizing  
or tanning agents may be formaldehyde  
in solution or as a vapor, sodium carbonate  
solution of gallic and tannic acids, chromium  
15 trioxide and chrome alum or other chrome  
and aluminum salts.

My preferred practice is to submerge the  
paper in a bath consisting of one part commercial  
formaldehyde and nine parts water  
20 by volume. The lapse of time between saturating  
with glue-glycerine water solution and formaldehyde  
does not seem to materially affect the quality  
of the paper. Formaldehyding on one side only,  
25 that is, the application of formaldehyde to one  
face of the previously treated paper, is preferred  
for purposes which will hereinafter appear  
where it is desired to further coat the untreated  
surface and leave the opposite surface  
30 substantially inactive.

The formaldehyding on one face only has  
the advantage that immediate insolubilizing  
or tanning may be practiced and further,  
35 treating one side only is less strain on a paper  
than complete submersion, particularly where  
the formaldehyde is in the form of a solution  
and the saturated paper before the excess water  
is evaporated is of low tensile strength and  
40 therefore less subject to tear or break. The  
treated surface is then submitted to a neutralizing  
action and where formaldehyde is used for the  
insolubilizing or tanning action, I may accomplish  
neutralization by subjecting the paper to a lime  
45 water treatment. It is preferred, however, to  
submit the formaldehyded web to a heat treatment.  
A temperature of 140 to 160° F. is used to  
thoroughly dry and volatilize all surplus formaldehyde.

50 It will be observed that I have described the  
saturation and the insolubilizing or tanning  
of the glue base as separate steps. However,  
the tanning or insolubilizing agent may be  
incorporated in the saturating solution above  
55 described, the tanning action or insolubilizing  
action of the glue being accomplished simultaneously  
with the drying of the saturating solution. For  
this purpose there is added to the saturating  
solution the tanning or insolubilizing agent. Where  
60 I use formaldehyde, I put an aldehyde compound  
into the glue solution prior to the saturation step.  
It is preferred to retard the action of the aldehyde  
so that the insolubilizing or tanning of the  
65 glue is accomplished in the drying step.

This retarding activity is accomplished by  
taking any aldehyde compound, such as formaldehyde,  
and adding ammonia thereto. In practice, equal  
molecular percentages of formaldehyde and ammonia  
are used in amounts equivalent to 5% of the aldehyde  
to the dry weight of the glue. 70

The saturating solution thus modified is  
used in the manner previously described. In the  
drying of the paper, the aldehyde-ammonia  
75 compound breaks down to liberate formaldehyde,  
setting up, insolubilizing or tanning the glue.

Though mere exposure by air drying of the  
saturated paper will sufficiently insolubilize  
80 the glue, due to the decomposition of the ammonia-  
formaldehyde compound, to liberate formaldehyde,  
however, it is preferred to hasten this decomposition  
by heating the saturated web. Ordinarily a temperature  
85 of approximately 80° C. will be sufficiently rapid.  
However, it is preferred to use a temperature  
between 100 to 120° C., which has been found  
to sufficiently set the glue with a speed of  
operation conducive to best practice. 90

The sheet so saturated and heat treated will  
have the glue or gelatine base substantially  
insoluble and, in a sense, waterproof. The  
paper base will be particularly strengthened  
95 and be resistant to sudden shock or stress,  
making it admirably suited for wrapping  
purposes. Particularly desirable elastic  
properties will be obtained where the paper  
base is of the toweled or creped variety where-  
100 in actual elasticity is imparted to the paper  
in that it retains the crimping or creping  
originally formed or molded in the paper and  
the tensile strength is materially increased  
and is tougher in a wet state when carrying  
105 its minimum amount of water content, apparently  
due to a vulcanizing or glueing together of  
the fibres of the paper into a solid mass. The  
flexibility augmenting agent further provides a  
sheeted material resistant to bearing when  
110 sharply folding the same.

Where I have described the use of dry  
glue with pale yellow glycerine, it will be  
observed that good results have been obtained  
with cheaper material such as low grade glue  
115 and using the crude rather than the pale yellow  
glycerine. Other flexibility augmenting agents  
as a modifier for the glue in place of the  
glycerine may be used. For certain purposes,  
particularly as will hereinafter be described,  
120 sulphonated oils such as Turkey red oil,  
sulphonated castor oil, may be used. These  
materials are not hygroscopic and tend to check,  
to a certain extent, the tendency to absorb  
and carry too much water. While I may use  
125 hygroscopic agents in general, for modifying  
the glue to retain a certain amount of water  
content inducing flexibility, it is preferred to  
use organic modifiers and for this purpose a  
sugar content fused in the glycerine of the  
130 saturating liquid has been found to be

particularly desirable. A paper web saturated with glue, formaldehyded or tanned as above described, has been found to be water-proof and particularly suitable as a base for forming the adhesive tape previously described when there is coated thereover the pressure aggressive, non-drying rubber base adhesive previously described.

By a "unified cellulosic backing" I mean to include a web of fabric comprising paper chosen from the materials herein described including gelatinized cellulosic sheets, such as parchmented paper, preferably treated with glycerine; paper treated with a composition consisting of glue, preferably modified by a softening agent, such as glycerine; paper surfaced with an insoluble rubber, such as chlorinated rubber; paper surfaced with an insoluble varnish compound, such as an insoluble resinous condensation product, the products whereof have the materials of the sheet in a condition so that when coated with a normally pressure sensitive adhesive, the elements of the sheet will be protected and held together against separation and with greater adhesion inter se than the adhesive coating has for the material to which the adhesive coating is affixed, to permit removal of the sheet from work to which it is applied or from rolls or stacks of such sheets, without substantial splitting or lamination of the sheet.

By a "unified pressure sensitive adhesive" I mean to include a coating which is normally adhesive by pressure as in applying a tape to a body material in which adhesion is effected without the necessity of energizing the adhesive by a moistening agent, and which has greater adhesion to the backing to which it is applied and cohesion inter se than adhesion to the surface to which it is temporarily applied, to permit its use for the purposes herein outlined, without substantial breaking, separation or lamination.

By "normally pressure sensitive adhesive" I mean to include a coating which normally is adhesive by pressure, as in applying a tape to a body material in which adhesion is effected without the necessity of energizing the adhesive by a moistening agent.

By "a paper which is distortable" I mean to include a web of material made by a paper making process and which is formed with rugosities by toweling or creping.

The specially treated paper and its adhesive coating duplicate results attainable heretofore only with cloth backing and, in addition, has marked advantages thereover. The paper base adhesive tape—

(1) Produces a flexible sheet with more body and density than cloth, particularly where a creped or toweled paper is used;

(2) High tensile strength is obtained by loading the paper with glue, particularly when acted upon by an insolubilizing, tan-

ning or formaldehyding agent. This renders the glue incapable of dissolving in water, which permits it to retain a considerable amount of its strength when in contact with water and hygroscopic materials which may constitute the adhesive film. When glycerine or other modifying elements are used, the saturated sheet is particularly flexible and resistant to breaking thereof by bending;

(3) The saturating and coating accomplish an action of welding, vulcanizing or glueing together of the paper fibres into one solid sheet, which makes impossible any laminating or splitting of the tape when removed from a surface to which it has been applied for some time or when put up in rolls without the use of slip sheeting;

(4) The treatment, particularly the saturating treatment of the paper, particularly when accompanied by insolubilizing, tanning or formaldehyding, also makes impossible any surface fibres breaking away or tearing away from the backing and sticking to the adhesive film when unwound from a roll. Thus, no modification of the adhesive film is effected.

(5) The hygroscopic agent, such as glycerine, retained in the saturated paper, maintains a water content in the paper backing of which it is a part. The adhesive film is therefore prevented from anchoring itself too securely to the reverse side of the backing, that is, a non-drying adhesive secures a hold or adheres to a dry surface much more thoroughly than to one which is moist or damp. Also, as the glue saturated paper has been insolubilized, tanned or formaldehyded, the adhesive coating will not unite with the backing as there is no solution possible between the rubber base adhesive and an insolubilized gelatin.

(6) The paper affords a material cheaper than cloth, which will not stretch as cloth does and, in a painting operation, which enables the user to preserve the same for stripping and the like painting or finishing operations. The paper base or backing being relatively thin, permits sharper definition in a painting operation for two tone color jobs as it lies substantially in the plane of the body to which it is affixed. Furthermore, the edge of a paper backed adhesive tape presents no feather edge nor will it unravel as cloth backing will, making it additionally desirable in painting operations.

(7) The paper backing with an adhesive layer at the edges thereof has the covering capacity of the full width of the paper but with minimum adhesion, permitting an economy in the adhesive coating, a ready removal from the body to which it is applied, avoiding the danger of marring the surface to which it is applied, may be unrolled or separated from an adjacent sheet with great facility and, in general, the paper backed



adhesive tape widens the field of utility due to cheapening the cost of the entire article.

Having thus described my invention and illustrated its use, what I claim as new and desire to secure by Letters Patent, is—

- 5 1. As a new article of manufacture, a sheeted material including a creped or towed fabric base and a pressure sensitive adhesive coating on one face thereof.
- 10 2. As a new article of manufacture, a removable adhesive tape comprising a paper backing formed with rugosities by creping or toweling and a pressure sensitive adhesive coating on one face thereof.
- 15 3. As a new article of manufacture, an adhesive sheet comprising a unified cellulosic backing and a pressure sensitive adhesive coating united to one surface of the backing.
- 20 4. As a new article of manufacture, an adhesive sheet comprising a unified cellulosic backing and a pressure sensitive adhesive coating united to one surface of the backing, the other surface of the backing being repellent to the adhesive.
- 25 5. As a new article of manufacture, a sheeted material including a water insoluble unified pressure sensitive adhesive united to one surface of a cellulosic backing, the opposite surface of said backing being unified by a repellent for said adhesive.
- 30

In testimony whereof I have hereunto signed my name.

RICHARD GURLEY DREW.

35

40

45

50

55

60

65